

“ ” : 2 PRONGS FOR STRANDED WIRE
多芯線用二叉型金片

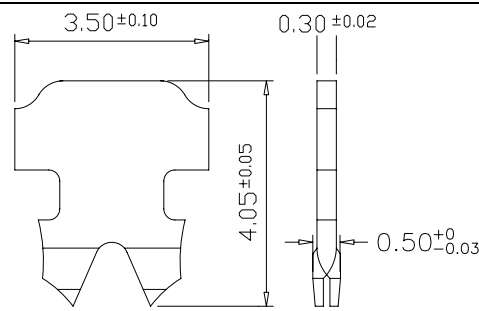

“ 2 ” : 2 PRONGS FOR SOLID WIRE(SS)
單芯線用大拐角型金片

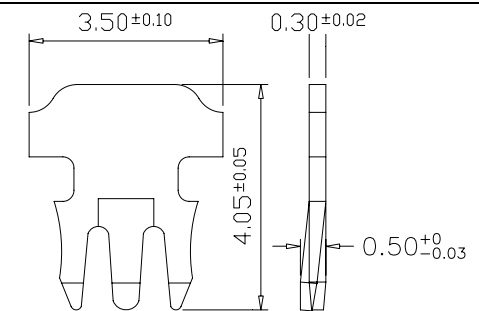

“ 3 ” : 3 PRONGS FOR SOLID WIRE(S)
單芯線用三叉型金片

材質及商標 Material & Brand (Logo) :

- 商標 Brand (LOGO) : (COB 空白 No Brand 客戶指定商標 Others_____)
- 塑膠材質 Housing Material : (Polycarbonate(PC) UL 94V-0 UL 94V-2)
- 金片型式 Contact Type : (二叉型金片 2 prongs for STRANDED wire 大拐角金片 2 prongs for SOLID wire 三叉金片 3 prongs for SOLID wire)
- 鍍金厚度 Gold Plating : (Fμ”(Flash) 3μ”(≥0.0762μm) 6μ”(≥0.1524μm) 15μ”(≥0.381μm) 30μ”(≥0.762μm) 50μ”(≥1.27μm))
- 金片材質 Contact Material : (青銅 Bronze 磷青銅 Phosphor Bronze)

UNIT: m/m

Remark:

- 適用 24 或 26 AWG 線材。 Available for 24 or 26 AWG wire.

COBLE ENTERPRISE CO., LTD.

TITLE	#102S1L*-** MP8P8C SHORT		
APPROVE	PETER KUO	DESIGN	C.M.CHEN
DATE	7-15-2011	F. No.	102S1L